

EPAS Kit-2 Helpful Hints when fitting our EPAS Kit to Manual Steering Systems.

The EPAS Kit-2 Unit must be installed in-between the steering wheel and the steering unit in the vehicle.

The photos below show what needs to be modified to fit one of our EPAS Kit-2 units to a manual steering System.

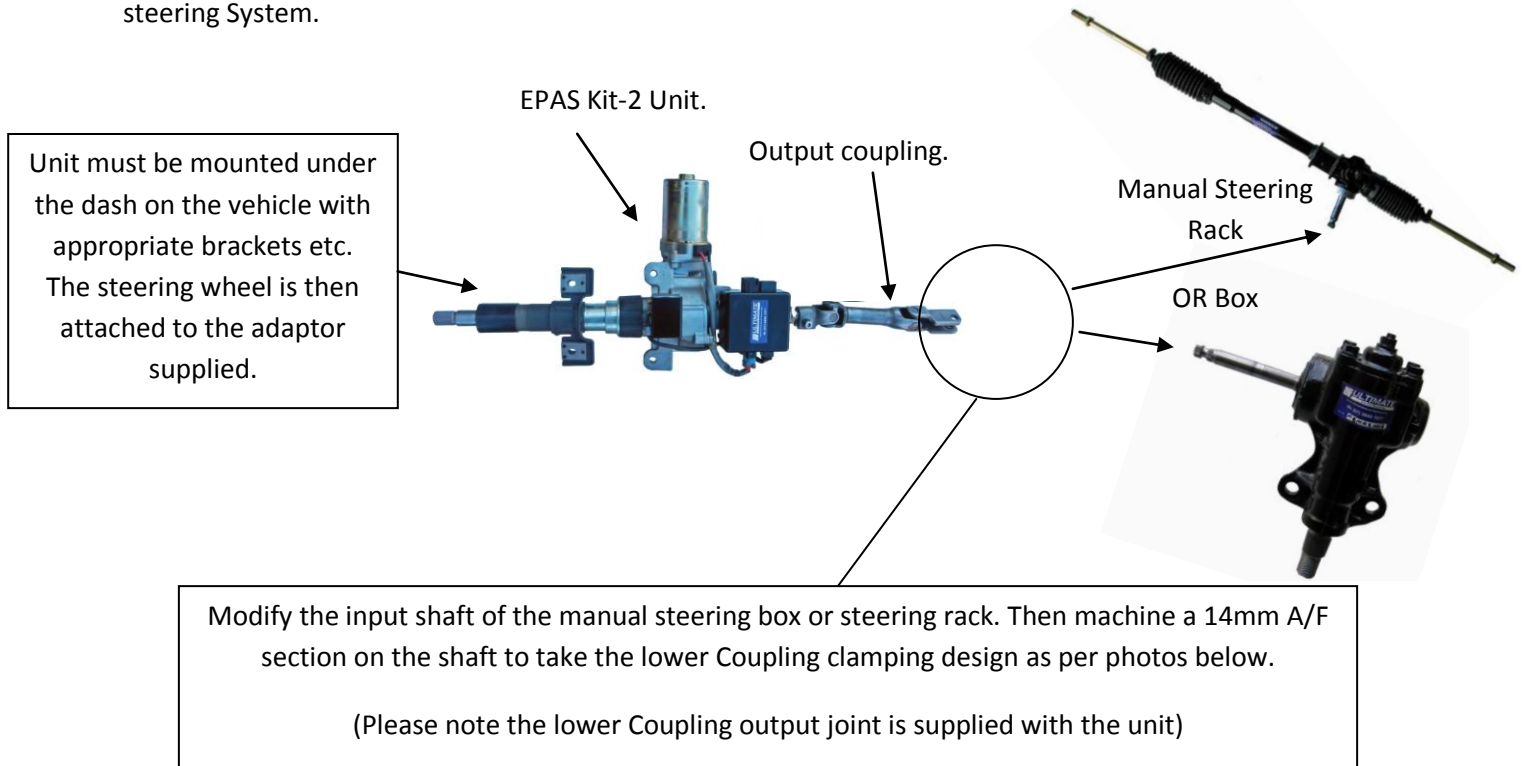

14mm A/F section on input shaft to fit lower output coupling.

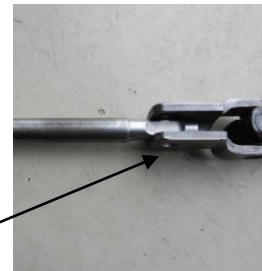

Once the unit is installed then the system can be wired up as per the instructions.

For more information please contact Ultimate Power Steering (07) 3889 7077 or visit our website.